

Product Manual



FSM 2.0 - STO

for the item Servo Positioning Controller C Series

Translation of the original instructions

Copyrights

© 2016 item Industrietechnik GmbH. All rights reserved.

The information and data in this document have been composed to the best of our knowledge. However, deviations between the document and the product cannot be excluded entirely. For the devices and the corresponding software in the version handed out to the customer, item guarantees the contractual use in accordance with the user documentation. In the case of serious deviations from the user documentation, item has the right and the obligation to repair, unless it would involve an unreasonable effort. A possible liability does not include deficiencies caused by deviations from the operating conditions intended for the device and described in the user documentation.

item does not guarantee that the products meet the buyer's demands and purposes or that they work together with other products selected by the buyer. item does not assume any liability for damages resulting from the combined use of its products with other products or resulting from improper handling of machines or systems.

item reserves the right to modify, amend, or improve the document or the product without prior notification.

This document may, neither entirely nor in part, be reproduced, translated into any other natural or machine-readable language nor transferred to electronic, mechanical, optical or any other kind of data media, without expressive authorisation by the author.

Trademarks

Any product names in this document may be registered trademarks. The sole purpose of any trademarks in this document is the identification of the corresponding products.

item Motion Soft™ is a registered trademark of item Industrietechnik GmbH.

Revision Information	
Author:	item Industrietechnik GmbH
Manual title:	Product Manual "FSM 2.0 - STO"
File name:	P-HB_FSM_STO_item Steuerung_C_EN.docx
Version:	April 2016

Identification of hazards and instructions on how to prevent them:



Danger

Immediate hazards which will result in death or severe personal injury.



Warning

Hazards that can cause death or serious injury.



Caution

Hazards that can cause minor injury or serious property damage.

Other symbols:



Note

Property damage or loss of functionality.



Recommendations, tips, references to other documentation



Essential or useful accessories



Information on environmentally sound usage

Text designations:

- Activities that may be carried out in any order.
- 1. Activities that may be carried out in the order stated.
- General lists

TABLE OF CONTENTS

1	SAFETY AND REQUIREMENTS FOR PRODUCT USE.....	12
1.1	Safety.....	12
1.1.1	General safety information.....	12
1.1.2	Intended use	13
1.1.3	Possible incorrect application	13
1.1.4	Achievable safety level, Safety function according to EN ISO 13849-1 / EN 61800-5-2.....	14
1.2	Requirements for product use	14
1.2.1	Technical requirements.....	14
1.2.2	Qualification of the specialist personnel (requirements for personnel).....	14
1.2.3	Diagnostic coverage (DC).....	15
1.2.4	Range of applications and certification.....	15
2	PRODUCT DESCRIPTION FOR THE SAFETY MODULE FSM 2.0 – STO.....	16
2.1	Product overview.....	16
2.1.1	Purpose.....	16
2.1.2	Supported devices.....	16
2.1.3	Control sections and connections.....	17
2.1.4	Scope of supply.....	18
2.2	Function and application	18
2.2.1	Description of the safety function STO	19
2.2.2	Overview of interface [X40]	20
2.2.3	Control ports STO-A, 0V-A / STO-B, 0V-B [X40]	21
2.2.3.1	Discrepancy time	22
2.2.3.2	Test pulse	22
2.2.4	Feedback contact C1, C2 [X40]	22
2.2.5	Auxiliary supply 24V, 0V [X40]	22
2.2.6	Status display.....	23
2.2.7	DIP switch.....	23
2.3	Functionalities in the item C Series	23
2.4	Time behaviour	25
2.4.1	Basic time behaviour STO	25

2.4.2	Time behaviour for activating STO during operation with restart	26
2.4.3	Time behaviour for activating SS1 during operation with restart	28
3	ASSEMBLY AND INSTALLATION	30
3.1	Mounting / Dismounting.....	30
3.1.1	Mounting the safety module	31
3.1.2	Dismounting the safety module	31
3.2	Electrical installation	32
3.2.1	Safety instructions.....	32
3.2.2	ESD protection	32
3.2.3	Connection [X40].....	32
3.2.4	Minimum wiring for commissioning [X40].....	33
3.3	Typical circuits	34
3.3.1	Safe Torque Off (STO)	34
3.3.2	Delays and safe torque switch off (SS1, “Safe Stop 1”).....	35
4	COMMISSIONING	37
4.1	Before commissioning	37
4.2	DIP switch setting.....	37
4.3	Parameterisation with item Motion Soft™	38
4.3.1	Type indication servo drive and safety module.....	39
4.3.2	Status indication of the state machine.....	39
4.3.3	Window “Safety module”	40
4.3.3.1	Info	42
4.3.3.2	Status-LEDs.....	42
4.3.3.3	Apply module type.....	43
4.4	Function test, validation.....	44
5	OPERATION	46
5.1	Obligations of the operator	46
5.2	Maintenance and care	46
5.3	Protective functions.....	46
5.3.1	Voltage monitoring.....	46
5.3.2	Protection against overvoltage and reverse polarity.....	46

5.4	Diagnostics and troubleshooting	47
5.4.1	Status indicators	47
5.4.1.1	Display on the safety module.....	47
5.4.1.2	Display on the servo drive.....	47
5.4.2	Error messages.....	47
6	CONVERSION AND MODULE REPLACEMENT.....	49
6.1	Safety module replacement	49
6.1.1	Repair	49
6.1.2	Removal and installation.....	49
6.2	Decommissioning and disposal.....	49
6.2.1	Disposal.....	49
7	TECHNICAL APPENDIX	50
7.1	Technical data.....	50
7.1.1	Safety engineering	50
7.1.2	General.....	51
7.1.3	Operating and environmental conditions	52
7.1.4	Electrical data.....	53
8	GLOSSARY.....	56

TABLE OF FIGURES

Figure 1:	Type key, example FSM 2.0 – STO	10
Figure 2:	Operator panel and connections FSM 2.0 – STO	17
Figure 3:	“Safe Torque Off” – Operating principle for the item C Series	19
Figure 4:	Basic time behaviour when activating and deactivating the safety function STO	25
Figure 5:	Time behaviour when activating the safety function STO with restart	26
Figure 6:	Time behaviour when activating the safety function SS1 (external switching) with restart	28
Figure 7:	Mounting/Dismounting	31
Figure 8:	Connection of the safety module FSM 2.0 - STO, example of single-phase item C 1-Series	34
Figure 9:	Typical circuit “Decelerate and safe torque off” (SS1, “Safe Stop 1”), example single-phase item C 1-Series	35
Figure 10:	Indication of the type of safety module and extended status window	39
Figure 11:	Menu navigation to Safety-module	41

TABLE OF TABLES

Table 1:	Documentation on the item servo positioning controller C Series.....	11
Table 2:	Overview of the safety modules and fieldbus activation modules for the item C Series	16
Table 3:	Scope of supply FSM 2.0 – STO	18
Table 4:	Function of the module connections.....	21
Table 5:	Detection and response times of the driver supply voltage.....	24
Table 6:	Time data concerning Figure 4	25
Table 7:	Time data concerning Figure 5	27
Table 8:	Time data concerning Figure 6	29
Table 9:	Pin assignment [X40]	33
Table 10:	Meaning of the LEDs for the status display in the window “Safety module”	42
Table 11:	Questions for validation in accordance with EN ISO 12100-1:2010 (example)	44
Table 12:	Questions for validation in accordance with EN ISO 13849-1 and 2 (example)	45
Table 13:	LED display on the safety module.....	47
Table 14:	Seven segment display on the servo drive	47
Table 15:	Error messages relating to the safety module.....	48
Table 16:	Technical data: Safety indicators.....	50
Table 17:	Technical data: Safety specifications.....	51
Table 18:	Technical data: Mechanical.....	51
Table 19:	Technical data: Certification.....	51
Table 20:	Technical data: Transport.....	52
Table 21:	Technical data: Storage	52
Table 22:	Technical data: Ambient conditions	52
Table 23:	Technical data: Electrical for ports STO-A and STO-B	53
Table 24:	Typical switch-off time and minimum tolerance time for test pulse (OSSD signals)	53
Table 25:	Technical data: Electrical data of the feedback contact C1/C2.....	54
Table 26:	Technical data: Electrical data of the auxiliary supply output	54
Table 27:	Technical data: Electrical isolation [X40].....	54
Table 28:	Technical data: Cabling to [X40].....	55
Table 29:	Terms and abbreviations This page is not for printing, it is only for cross-reference-declaration:.....	56

Instructions on this product manual

This product manual is to ensure work with the safety function STO - "Safe Torque Off" in accordance with EN 61800-5-2 is performed safely by using the safety module FSM 2.0 – STO for the **item servo positioning controller C Series**.

- In addition, always observe the "Safety notes for electrical drives and controllers" on the item C Series.



You will find the "Safety notes for electrical drives and controllers" on the item C Series in the product manuals according to Table 1.

Observe the information regarding safety and on the requirements for product use in Section 1.2.

Product identification



This product manual refers to the following versions:

- Safety module FSM 2.0 - STO, from revision 1.5.
- item C Series, firmware from version 4.1.7001.1.1.
- Parameterisation program item Motion Soft™ from version 1.0

Type key

The Functional Safety Modules are available in different types of integrated functional safety.

Example FSM 2.0 – STO

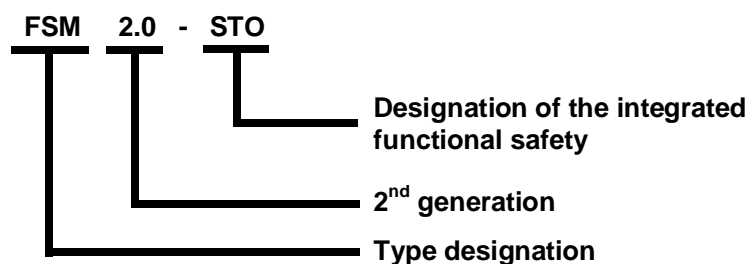

Figure 1: Type key, example FSM 2.0 – STO

Support

For technical questions please contact your reseller.

Documentation

You will find additional information on the servo drives in the following documentation:

User documentation on the item servo positioning controller C Series	
Name, type	Contents
Product Manual "item Servo Positioning Controller C 1-Series"	Description of the technical data and the device functionality plus notes concerning the installation and operation of C 1-02, C 1-05 and C 1-08 servo drives.
Product Manual "item Servo Positioning Controller C 3-Series"	Description of the technical data and the device functionality plus notes concerning the installation and operation of C 3-05 and C 3-10 servo drives.
Product Manual "FSM 2.0 – STO"	Description of the functional safety technology for the item servo positioning controller C Series with the safety function STO (this product manual).
Software Manual "item Servo Positioning Controller C Series"	Description of the device functionality and the software functions of the firmware including the RS232 communication. Description of the item Motion Soft™ parameterisation program with instructions concerning the start-up of the item servo positioning controller C Series.
Mounting Instructions "item Servo Positioning Controller C 1-Series"	Instructions on the installation of the C 1-02, C 1-05 and C 1-08.
Mounting Instructions "item Servo Positioning Controller C 3-Series"	Instructions on the installation of the C 3-05 and C 3-10.

Table 1: Documentation on the item servo positioning controller C Series

You can find all these documents on our homepage at the download area <http://www.item24.com>.

1 Safety and requirements for product use

1.1 Safety

1.1.1 General safety information

In addition, always observe the “Safety notes for electrical drives and controllers“ on the item servo positioning controller C Series.



You will find the “Safety notes for electrical drives and controllers“ on the item servo positioning controller C Series in the product manuals according to Table 1.



Note

Danger of loss of the safety function.

Non-compliance with environmental and connection conditions can lead to loss of the safety function.

- Observe the specified environmental and connection conditions, in particular the input voltage tolerances → Technical data, Appendix 7.1.



Note

Incorrect handling can damage the safety module or the servo drive.

- Before mounting and installation work, switch off the supply voltage. Switch on the supply voltage only when the mounting and installation work is complete.
- Never unplug a module from, or plug a module into the servo drive when it is energised!
- Observe the handling specifications for electrostatically-sensitive devices.



1.1.2 Intended use

The safety module FSM 2.0 – STO serves as an expansion of the item servo positioning controller C Series to achieve the safety function:

- Safely switched-off torque – “Safe Torque Off” (STO) with SIL3 according to EN 61800-5-2 / EN 62061 / IEC 61508 or category 4 / PL e according to EN ISO 13849-1.

The item servo positioning controller C Series with safety module FSM 2.0 – STO is a product with safety-relevant functions and is intended for installation in machines or automation systems and for use as follows:

- in a faultless technical condition,
- in its original condition, without any modifications by the user,
- within the product’s limits as defined by the technical data (→ Appendix 7.1),
- in an industrial environment.

The Functional Safety Modules FSM 2.0 can be operated in all servo drives of the item C Series. Those are equipped with the slot for safety modules (“FSM slot”). The safety modules cannot be inserted into one of the extension slots for technology modules (TECH1 or TECH2).



Note

In the event of damage caused by unauthorised manipulation or use other than intended, the guarantee is invalidated and the manufacturer is not liable for damages.

1.1.3 Possible incorrect application

Improper use includes the following possible cases of incorrect application:

- use in a device other than the item C Series,
- use outdoors,
- use in a non-industrial area (residential area),
- use in applications where switching off can result in hazardous movements or conditions.



Note

- The STO function is insufficient as the sole safety function for drives subject to permanent torque (e.g. suspended loads).
- Bypassing of safety equipment is impermissible.
- Repairs on the module are impermissible!



The STO (Safe Torque Off) function does **not** provide protection against electric shock, only against hazardous movements!

→ Product manual item C 1-Series and product manual item C 3-Series

1.1.4 Achievable safety level, Safety function according to EN ISO 13849-1 / EN 61800-5-2

The safety module fulfils the basic test requirements

- Category 4 / PL e according to EN ISO 13849-1,
- SIL CL 3 according to EN 61800-5-2 / EN 62061 / IEC 61508,

and can be used in applications up to cat. 4 / PL e according to EN ISO 13849-1 and SIL 3 according to EN 62061 / IEC 61508.

The achievable safety level depends on the other components used to achieve a safety function.

1.2 Requirements for product use

Make this documentation available to the design engineer and installer or person responsible for commissioning the machine or system in which this product will be used.

Ensure compliance with specifications in the documentation at all times. Also take into account the documentation for the other components and modules (e.g. servo drive, lines, etc.).

Take into account the legal regulations applicable to the destination, as well as:

- regulations and standards,
- regulations of the testing organisations and insurers,
- national specifications.

For emergency stop applications, protection against automatic restart must be provided according to the required safety category. This can be achieved through an external safety switching device, for example.

1.2.1 Technical requirements

General conditions for the correct and safe use of the product, which must be observed at all times:

Comply with the connection and environmental conditions of the safety module (→ Appendix 7.1), the servo drive and all connected components.

The product can be operated in accordance with the relevant safety guidelines only if the limit values or load limits are observed.

Observe the warnings and instructions in this documentation.

1.2.2 Qualification of the specialist personnel (requirements for personnel)

The device may only be placed in operation by a qualified electrical engineer who is familiar with:

- installation and operation of electrical control systems,
- the applicable regulations for operating safety-engineered systems,
- the applicable regulations for accident protection and occupational safety, and
- product documentation.

1.2.3 Diagnostic coverage (DC)

Diagnostic coverage depends on the connection between the servo drive with safety module and the control loop system as well as the implemented diagnostic measures.

If a potentially hazardous disturbance is recognised during diagnosis, appropriate measures for maintaining the safety level must be implemented.



Note

Check whether cross-circuit detection of the input circuit and the connection wiring is required in your application.

If needed, use a safety switching device with horizontal cross-circuit detection to activate the safety module.

1.2.4 Range of applications and certification

The servo drive with built-in safety module is a safety component in accordance with the machinery directive; the servo drive bears the CE mark.

Standards and test values which the product must comply with and fulfils can be found in the section "Technical data" (→ Appendix 7.1). The product-relevant EU directives can be found in the declaration of conformity.



Certificates and the declarations of conformity for this product can be found at <http://www.item24.com>.

2 Product description for the safety module FSM 2.0 – STO

2.1 Product overview

2.1.1 Purpose

As processes become increasingly automated, protecting people from potentially hazardous movements is gaining in importance. Functional safety describes the measures offered by electrical or electronic devices that are required to reduce or eliminate malfunction-induced hazards. In normal operation, safety devices prevent human intervention in hazardous areas. In certain operating modes, during set-up for example, people also need to be in hazardous areas. In such situations, the machine operator must be protected by drive and internal control measures.

Integrated functional safety technology provides the conditions required by controller and drive for the optimised realisation of safety functions. Planning and installation complexity is reduced. The use of integrated functional safety technology increases machine functionality and availability over the levels achieved by conventional safety technology.

Type	Description
FSM 2.0 – FBA	Fieldbus activation module with DIP switches, no safety functions .
FSM 2.0 – STO	Safety module with STO function and DIP switches.

Table 2: Overview of the safety modules and fieldbus activation modules for the item C Series

2.1.2 Supported devices

The safety module FSM 2.0 – STO can only be used in servo drives in conformity with Section 1.1.2.

As a standard, the item servo positioning controller C Series come supplied with the module FSM 2.0 – FBA without integrated functional safety mounted in the FSM slot.

The use of safety module FSM 2.0 – STO enables the safety functions, described in this product manual for the integrated functional safety of safety stops, to be expanded.



If no safety functions are required, the module FSM 2.0 – FBA must be inserted in the extension slot for safety modules (“FSM slot”).

2.1.3 Control sections and connections

The safety module FSM 2.0 – STO has the following control sections, connections and display components:

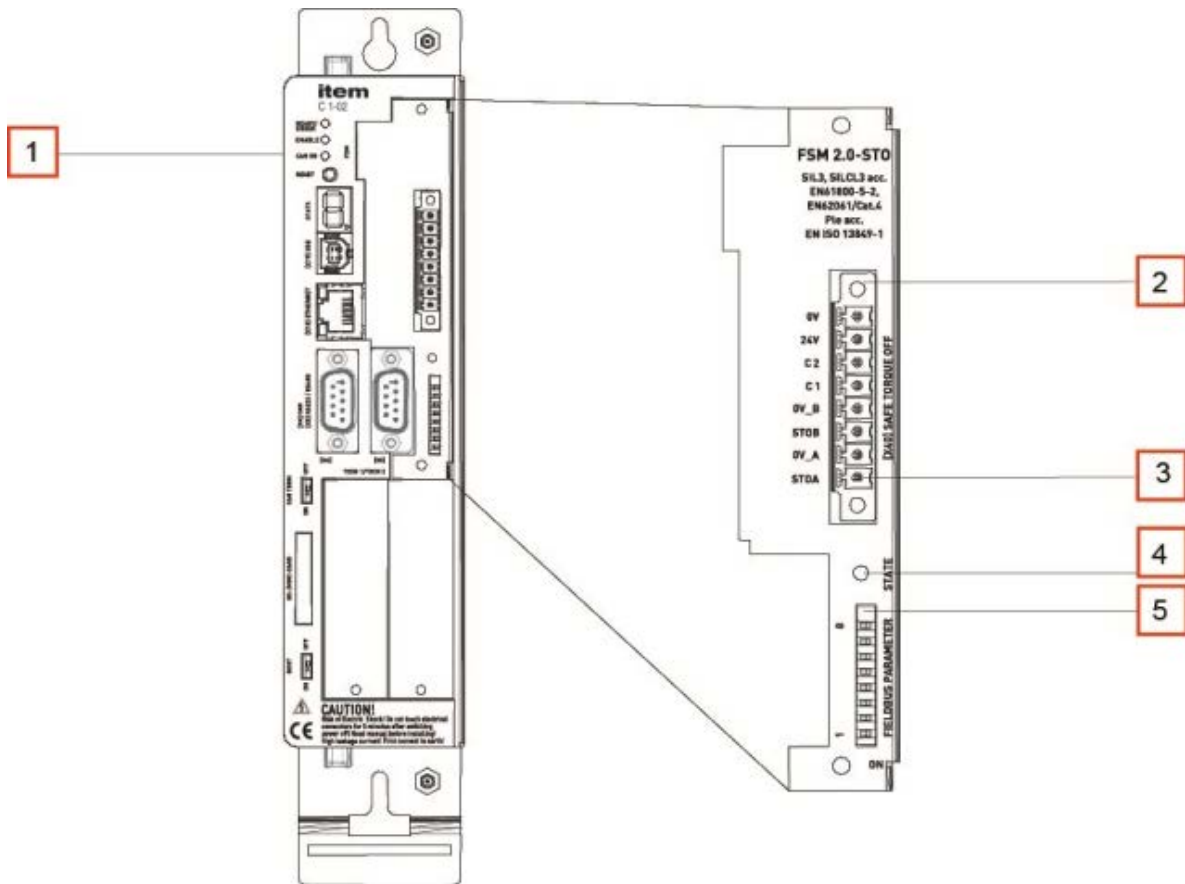

- 1 item servo positioning controller C Series with slot for a Functional Safety Module
- 2 Digital I/O-interface [X40] for control of the STO function
- 3 Pin 1 of the interface [X40]
- 4 LED for status display (functional safety status)
- 5 DIP-switch (activation/configuration of the fieldbus communication in the servo drive)

Figure 2: Operator panel and connections FSM 2.0 – STO

2.1.4 Scope of supply

1x	Functional Safety Module FSM 2.0 – STO	
	Type	FSM 2.0 – STO
	item part number	0.0.668.20
	Accessories	
	1x	Counter plug for control lines PHOENIX Mini-Combicon MC 1,5/8-STF-3,81 BK
	1x	Installation instructions German / English

Table 3: Scope of supply FSM 2.0 – STO

2.2 Function and application

The safety module FSM 2.0 – STO has the following performance characteristics:

- “Safe Torque Off” (STO) function,
- Potential-free feedback contact for the operating status,
- Designed as a plug-in module that can be plugged in from the outside thus enabling retrofits,
- Suitable solely for item servo positioning controller C Series.

The “Safe Stop 1” (SS1) function can be realised by employing a suitable external safety switching device and appropriate item C Series circuitry.

2.2.1 Description of the safety function STO

Use the function “Safe Torque Off” (STO) whenever you have to reliably disconnect the energy supply to the motor in your particular application.

The function “Safely Torque Off” switches off the driver supply for the power semiconductor, thus preventing the power end stage supplying the voltage required by the motor see Figure 3.

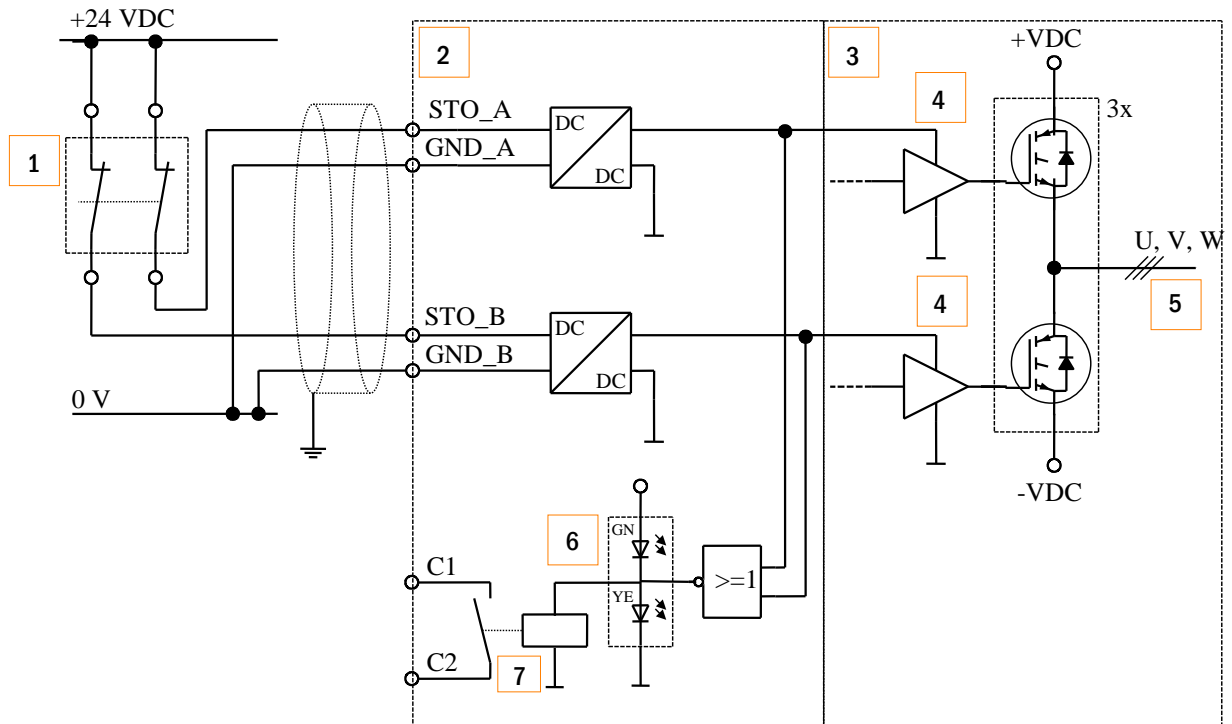

- 1 Safety circuit (switch, relay, safety switching device)
- 2 Safety module FSM 2.0 – STO
- 3 Power end stage in the item C Series (only one phase illustrated)
- 4 Driver supply
- 5 Motor connection
- 6 LED (green / yellow), status display
- 7 Feedback contact

Figure 3: “Safe Torque Off” – Operating principle for the item C Series

The power supply to the drive is reliably disconnected via the active safety function STO “Safe Torque Off”. The drive cannot generate torque and so cannot perform any hazardous movements. With suspended loads or other external forces, additional measures must be taken to reliably prevent sagging (e.g. mechanical holding brake). In the STO “Safe Torque Off” state, the standstill position is not monitored.

The machine must be stopped in a safe manner, e.g. via a safety switching device. This applies specifically to vertical axes without self-locking mechanism, clamping unit or counterbalance.

**Note**

There is a risk that the drive will advance in case of multiple errors in the item C Series.

If the output stage of the servo drive fails while in the STO status (simultaneous short circuit of 2 power semiconductors in different phases), a limited dwell movement of the rotor may result. The rotation angle / path corresponds to a pole pitch. Examples:

- Rotary axis, synchronous machine, 8-pin → movement < 45° at the motor shaft.
- Linear motor, pole pitch 20 mm → movement < 20 mm at the moving part.

2.2.2 Overview of interface [X40]

On its front, the safety module provides an 8-pin connection [X40] for control ports, feedback contact and a 24 V auxiliary supply for external sensors: → Section 3.2.

The safety function STO is requested solely via the two digital control ports STO-A and STO-B. A safety circuit for additional interfaces at the item C Series is neither required nor intended.



Cross-circuit detection in the input circuit is not carried out by the safety module.

The status of the servo drive is reported back to an external safety switching device through a potential-free acknowledgment contact (normally open).

The interface [X40] permits the direct connection of active and passive sensors, since a 24 V supply voltage (auxiliary supply) with corresponding reference potential is lead out.

Connections	Description
STO-A (Pin 1) 0V-A (Pin 2)	Control port A for the STO function with corresponding reference potential. ¹⁾ – Request for “Safe Torque Off” (STO) at Low (0 signal), together with STO-B.
STO-B (Pin 3) 0V-B (Pin 4)	Control port B for the STO function with corresponding reference potential. ¹⁾ – Request for “Safe Torque Off” (STO) at Low (0 signal), together with STO-A.
C1 (Pin 5) C2 (Pin 6)	Feedback contact for the “Safe Torque Off” (STO) status, e.g. to an external controller. – Feedback contact opened: “Safe Torque Off” (STO) not active – Feedback contact closed: “Safe Torque Off” (STO) active
24 V (Pin 7) 0 V (Pin 8)	Auxiliary supply, e.g. for safety peripherals (24 V DC logic supply of the servo drive).
1) Control inputs 24 V, high active, based on EN 61131-2, deviating signal level, see Section 7, Table 23.	

Table 4: Function of the module connections

The connections are electrically isolated from each other in groups and from the 24 V supply to the servo drive → Section 7, Table 26.

2.2.3 Control ports STO-A, 0V-A / STO-B, 0V-B [X40]

The safety function STO (Safe Torque Off) is requested via the two control ports STO-A and STO-B. They permit the direct connection of safe semiconductor outputs (electronic safety switching devices, active safety sensors, e.g. light curtains with OSSD signals) and of switch contacts (safety switching device with relay outputs, passive safety sensors, e.g. forcibly-guided position switches) → e.g. Section 3.2.3, Figure 8.

To request the safety function STO (Safe Torque Off), the 24 V control voltage at both control ports STO-A and STO-B is switched off (0 V).

If the two control ports are switched off simultaneously or within a defined discrepancy time, the STO function is active.

For control ports STO-A and STO-B, an undervoltage monitoring mechanism is integrated to eliminate the possibility of invalid voltage ranges for the downstream electronics, as well as an overvoltage monitoring mechanism to protect against overvoltage.



Table 23 in Section 7.1.4 describes the technical data for the control ports within the specified operating range of the logic voltages.

Tolerance ranges are defined for the input voltage range of control ports STO-A and STO-B. The amount of energy stored in the safety module components (e.g. capacitors) depends on the input voltage level. During switching operations, these energies must be charged or discharged. Consequently, switch-off time values for the transition to the safe state (STO) and the tolerance time vis-a-vis OSSD signals (buffer time) depend on the input level.

The time response requirements are contained in the technical specifications in Section 7.1.4. The time response itself is described in Section 2.4.

2.2.3.1 Discrepancy time

The transition between the safe and the unsafe state is initiated via level changes at the control ports STO-A and STO-B of the safety module FSM 2.0 – STO. According to the safety function specification, the two levels must be identical otherwise an error message will be generated. The finite state machine in the servo drive internally monitors the driver supply voltage after the control ports have been activated. Due to component tolerances or bouncing safety controller ports, for example, these level changes do not normally occur precisely at the same time. The firmware tolerates this for as long as the second input occurs within a defined time, the so-called discrepancy time. If this time is exceeded, the servo drive generates an error message.

The default discrepancy time is 100 ms.

Recommendation: Always switch STO-A and STO-B simultaneously.

2.2.3.2 Test pulse

Temporary test pulses from safety controllers are tolerated and thus do not trigger the STO function.

The tolerance to test pulses from sensors with OSSD signals is rated for the operating range specified in accordance with Appendix 7.1.4, Table 24. The permissible test pulse length is dependent upon the control voltage level at inputs STO-A and STO-B.

Example: Input voltage for STO-A and STO-B = 24 V

→ OSSD signals with a test pulse length of 3.5 ms are tolerated.

2.2.4 Feedback contact C1, C2 [X40]

If the **STO function is inactive**, the feedback contact opens. This is the case, for example, when only one of the two control voltages STO-A or STO-B is present, if the 24 V logic power supply is switched off or if the supply voltage fails.

When the **STO function is active**, the relay contact is closed.



The feedback contact has a single channel and may be used for diagnostic purposes, but not in the safety circuit.

Table 25 in Section 7.1.4 describes the electrical data, and the time response of the feedback contact.

When the 24 V supply to the basic device is turned on and off, the switching status of the relay may – due to the internal supply voltages powering up at a different speed – deviate briefly (approx. 100 ms) from the state of the control ports STO-A and STO-B.

2.2.5 Auxiliary supply 24V, 0V [X40]

The item C Series with safety module FSM 2.0 – STO provides a 24 V auxiliary supply to [X40]. This can be employed when using the feedback contact C1/C2 or to supply external, active sensors.



Table 26 in Section 7.1.4 describes the electrical data for the auxiliary supply.

2.2.6 Status display

To display the status of the safety function, the safety module has an LED on its front → Section 5.4.1.

The status LED displays the module's operating state (green = STO inactive, yellow = STO active). The display corresponds to the state of the feedback contact C1/C2.

2.2.7 DIP switch

Located on the front of the safety module are DIP switches. These switches have no safety function. The meaning of the individual switches depends on the technology module used for the fieldbus communication.

The fieldbus communication can be activated/deactivated or a station address can be set, for example, via the DIP switches.

2.3 Functionalities in the item C Series

The following functions in the item servo positioning controller C Series are not certified according to EN 61800-5-2. They are functional supplements and offer additional diagnostics options.

Error messages generated by the safety module, such as exceeding the discrepancy time, are detected and analysed by the non-safety finite state machine of the servo drive. If conditions for an error status are detected, an error message is generated. In this case, it cannot always be guaranteed that power end stage has been safely switched off.

The safety module FSM 2.0 – STO controls only the provisioning of the driver supply for the item C Series. Although input voltage levels are monitored area by area, the safety module does not have its own error analysis function and is unable to display errors.



Note

When error messages are acknowledged, all acknowledgeable errors regarding functional safety are also always acknowledged → Section 5.4.2.

The item servo positioning controller C Series monitors the status of the control ports STO-A and STO-B.

Consequently, the servo drive firmware detects the request for the safety function STO (Safe Torque Off) and various non-safety functions are then performed:

- Detection of deactivated driver supply for the power semiconductor via the safety module,
- Deactivation of the drive controller and activation of the power semiconductor (PWM),
- The holding brake controller is deactivated (if configured),
- Finite state machine on the servo drive with activation analysis (discrepancy time),
- Detection of application-related error messages,
- Hardware diagnostics,
- Status and error display via display, digital outputs, fieldbuses etc.



Note

The brake is activated by the servo drive's non-safety firmware.

**Note**

If one of the control ports STO-A or STO-B is deactivated with an active output, the drive coasts unbraked if no holding brake is connected.

This can cause damage to the machine. It is therefore recommended that a holding brake is connected to the servo drive.



Please check whether the motors with holding brake you use is designed to decelerate and bring the motor to a standstill via the holding brake, should malfunction occur.

The safe state can be requested when the power semiconductor (PWM) is activated. The two driver supply voltage states are detected and analysed in 10 ms cycles. If they are unequal over a prolonged period, an error message is generated: → Section 5.4.2. The safety function presupposes that the two signals have the same status. Unequal signals are tolerated only during a transition period, the so-called “discrepancy time”: → Section 2.2.3.

The finite state machine in the item servo positioning controller C Series has its own status in parallel to the safety module FSM 2.0 – STO. Due to the discrepancy time analysis, this finite state machine may reach the “Safe status” only with a considerable delay. Accordingly, this state can also be signalled via digital outputs or a fieldbus only with a considerable delay. The power end stage itself is then, however, “safely switched off”. This finite state machine is processed within the 10 ms cycle.

This generally results in a graded response speed as per Table 5:

Function	Response time	Reaction
Switching time from high to low	T_STO-A/B_OFF	→ Section 7.1.4, Table 23
Switching time from low to high	T_STO-A/B_ON	→ Section 7.1.4, Table 23
Detection of driver supply failure	$t_{\text{Reaction}} \leq 125 \mu\text{s}$	Activation of the power semiconductor (PWM) is switched off
Activation of holding brake	$t_{\text{Reaction}} \leq 10 \text{ ms}$	Activation of the holding brake after detection of the driver supply failure
Signal analysis and status display	$t_{\text{Reaction}} \leq 10 \text{ ms}$	Status transitions in the internal finite state machine, triggering an error message and showing the status on the display if necessary

Table 5: Detection and response times of the driver supply voltage

2.4 Time behaviour



Functionally, the STO-A and STO-B inputs are identical. The switch sequence of STO-A/STO-B is interchangeable across all diagrams.

2.4.1 Basic time behaviour STO

Figure 4 displays the basic time behaviour of the safety module. The time specifications can be found in Table 6:

FSM 2.0 - STO

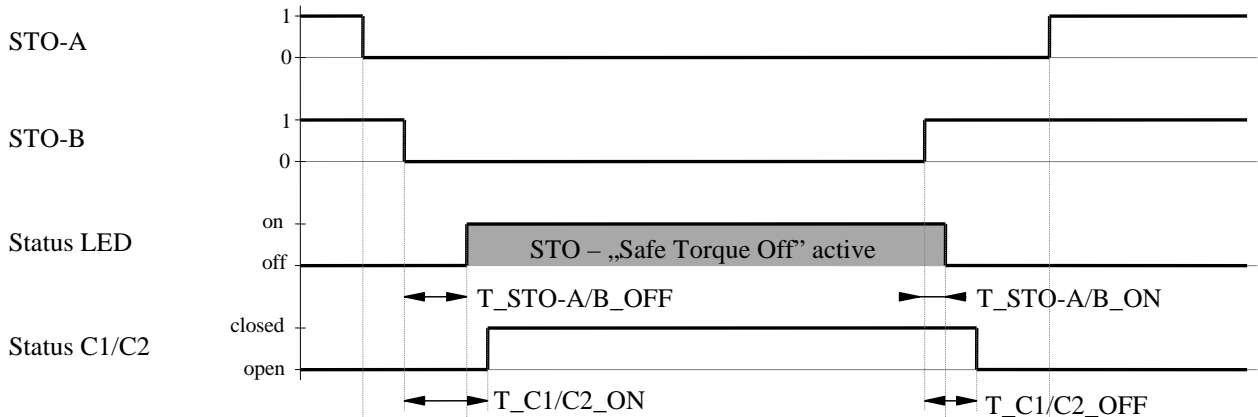

item C Series

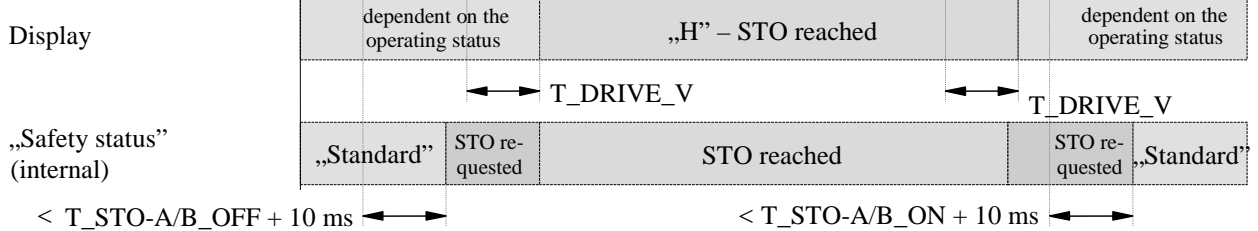

Figure 4: Basic time behaviour when activating and deactivating the safety function STO

Time	Description	Value
T_STO-A/B_OFF	STO-A/B – Switching time from High to Low	→ Section 7.1.4, Table 23
T_STO-A/B_ON	STO-A/B – Switching time from Low to High	→ Section 7.1.4, Table 23
T_C1/C2_ON	C1/2 – Switching time closing	→ Section 7.1.4, Table 23
T_C1/C2_OFF	C1/2 – Switching time opening	→ Section 7.1.4, Table 23
T_DRIVE_V	Delay of the item C Series	0 ... 10 ms

Table 6: Time data concerning Figure 4

2.4.2 Time behaviour for activating STO during operation with restart

Figure 5 displays the time behaviour starting from interruption of the control voltage to STO-A/B, as well as the sequence required to allow the device to restart. The time specifications can be found in Table 7. Notes:

- The holding brake is activated via the servo drive, not a safety function.
- The coasting of the motor, irrespective of brake activation/deactivation, is displayed.
- The setpoint value is only activated when the holding brake delay T_BRAKE_V has expired.
- An error is triggered because the STO inputs are deactivated while the output stage is active.

FSM 2.0 - STO

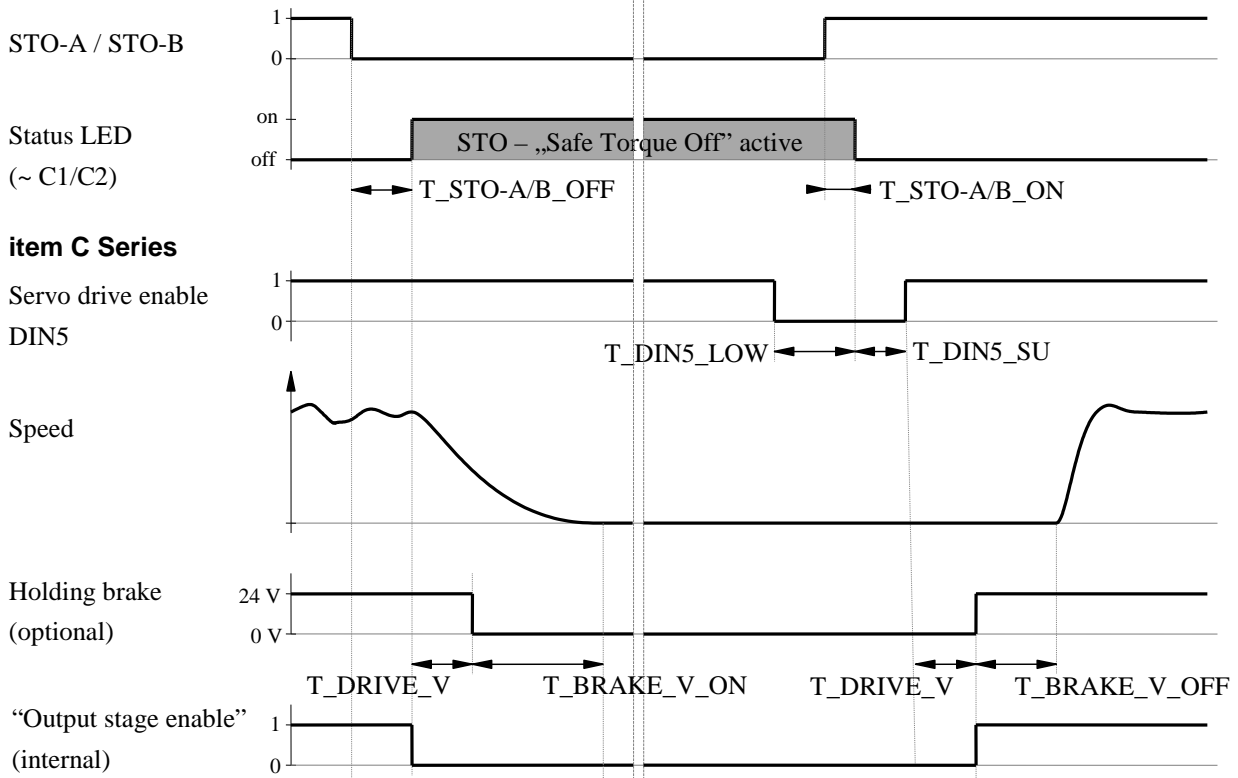

Figure 5: Time behaviour when activating the safety function STO with restart

Time	Description	Value
T_STO-A/B_OFF	STO-A/B – Switching time from High to Low	→ Section 7.1.4, Table 23
T_STO-A/B_ON	STO-A/B – Switching time from Low to High	→ Section 7.1.4, Table 23
T_DIN5_LOW	Time for which the DIN5 must be Low before STO-A/B is switched on again	0 ms
T_DIN5_SU	Time for which the DIN5 must be Low after switching on STO-A/B again and status change of the STO module	> 20 ms
T_DRIVE_V	Delay of the item C Series	0 ... 10 ms
T_BRAKE_V_ON	Switch off delay of the holding brake	Dependent on the brake ¹⁾
T_BRAKE_V_OFF	Switch on delay of the holding brake	Dependent on the brake ²⁾
<p>1) Physical delay until the brake closes.</p> <p>2) Minimum time: Physical delay until the brake opens. This time can be parameterised in the servo drive via a large value.</p>		

Table 7: Time data concerning Figure 5

2.4.3 Time behaviour for activating SS1 during operation with restart

The time behaviour in Figure 6 is based on the typical circuit for SS1 in Section 3.3.2, starting from control signal S1 for K1. The time specifications can be found in Table 8.

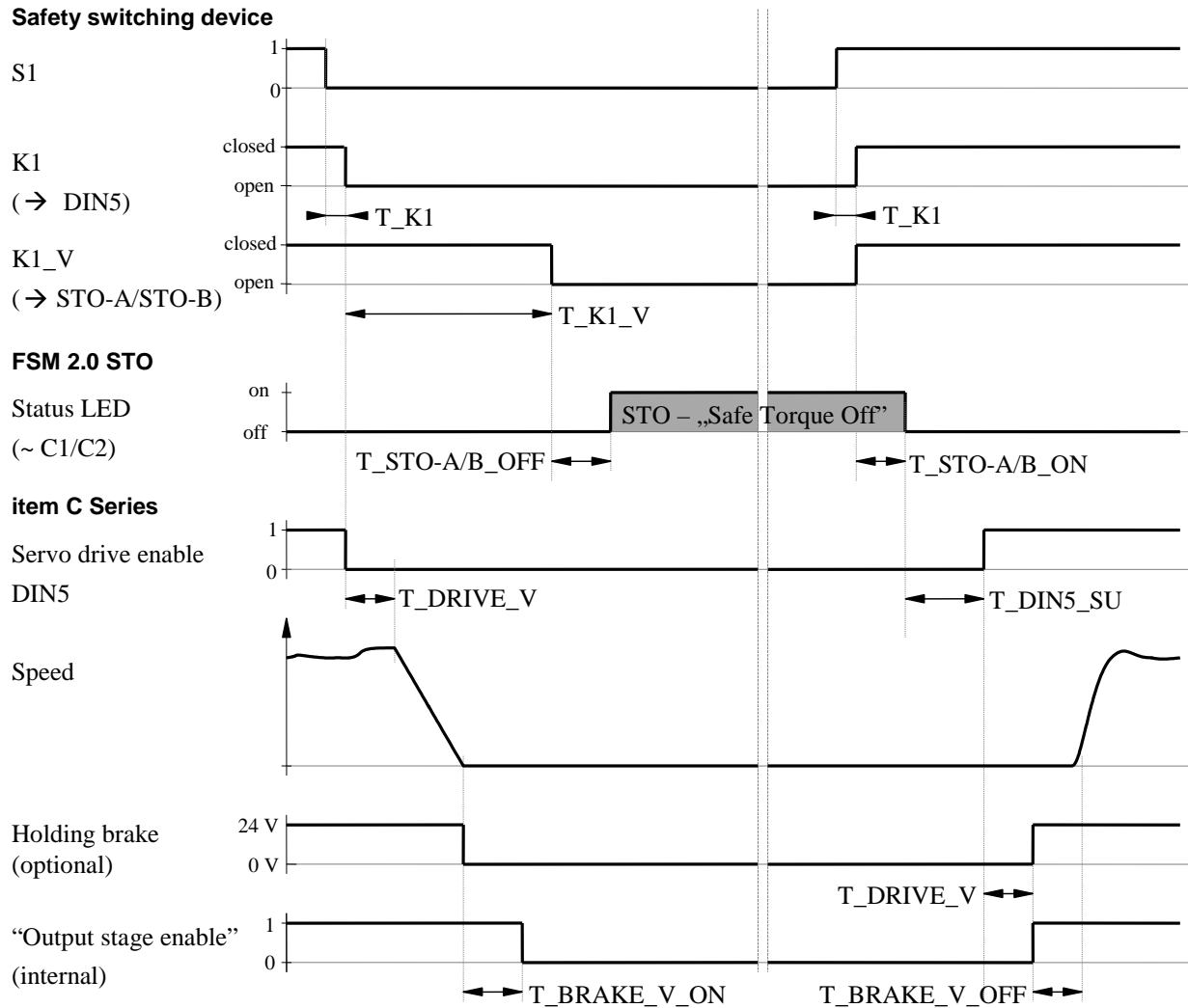

Figure 6: Time behaviour when activating the safety function SS1 (external switching) with restart

Time	Description	Value
T_K1	Delay between the switching of S1 and the closing of the undelayed contact K1	→ Data sheet for the safety switching device
T_K1_V	Delay between S1 and the opening of the relapse delayed contact K1	Can be set on the safety switching device
T_STO-A/B_OFF	STO-A/B – Switching time from High to Low	→ Section 7.1.4, Table 23
T_STO-A/B_ON	STO-A/B – Switching time from Low to High	→ Section 7.1.4, Table 23
T_DRIVE_V	Delay of the item C Series	0 ... 10 ms
T_DIN5_SU	Time for which the DIN5 must be Low after switching on STO-A/B again and status change of the STO module	> 20 ms
T_BRAKE_V_ON	Switch off delay of the holding brake	Dependent on the brake ¹⁾
T_BRAKE_V_OFF	Switch on delay of the holding brake	Dependent on the brake ²⁾
<p>1) Physical delay until the brake closes.</p> <p>2) Minimum time: Physical delay until the brake opens. This time can be parameterised in the servo drive via a large value.</p>		

Table 8: Time data concerning Figure 6

3 Assembly and Installation

3.1 Mounting / Dismounting

The safety module FSM 2.0 – STO is suitable only for integration into the item servo positioning controller C Series. It cannot be operated outside the servo drive.



Warning

Danger of electric shock if the safety module is not mounted.



Contact with conducting parts will cause severe injuries and may result in death.

Before touching conducting parts during maintenance, repair and cleaning work and during long service interruptions:

1. Switch off the power to the electrical equipment and secure it to prevent a restart.
2. After switching it off, wait at least 5 minutes of discharge time and check that it is voltage-free before accessing the servo drive.



Note

Incorrect handling can damage the safety module or servo drive.



- Before mounting and installation work, switch off the supply voltage. Switch on the supply voltage only when the mounting and installation work have been completely finished.
- Never unplug a module from, or plug a module into the servo drive when it is energised!
- Observe the handling specifications for electrostatically-sensitive devices. Do not touch the printed circuit board or the pins of the manifold rail in the servo drive. Hold the safety module only by the front plate or the edge of the board.

3.1.1 Mounting the safety module

1. Insert the safety module FSM 2.0 – STO into the extension slot for safety modules so that the board runs in the lateral guides of the slot.
2. Insert safety module; when the back of the contact strip within the servo drive is reached, carefully press it into the contact strip until it stops.
3. Then screw the safety module with the two screws onto the front of the servo drive housing.

Tighten the screws with approx. 0.35 Nm.

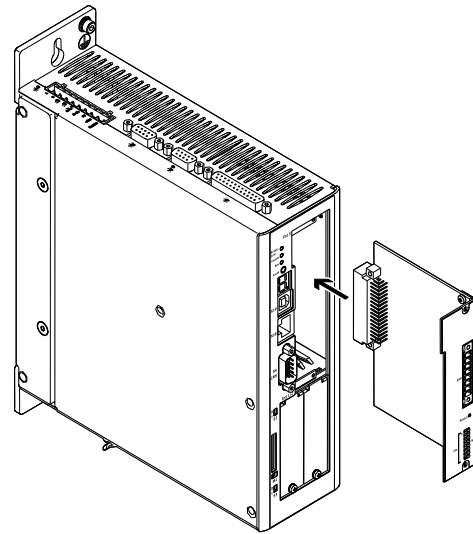

Figure 7: Mounting/Dismounting

3.1.2 Dismounting the safety module

1. Unscrew screws on the safety module.
2. Loosen the safety module by gently levering the front cover or by pulling on the counterplug by just a few millimetres.
3. Pull the safety module out of the slot.

3.2 Electrical installation

3.2.1 Safety instructions

During installation, the requirements of EN 60204-1 must be fulfilled.



Warning

Danger of electric shock in case of voltage sources without safety measures.



- Use only PELV (protective extra-low voltage) circuits according to EN 60204-1 for the electric logic supply. Also observe the general requirements for PELV power circuits according to EN 60204-1.
- Only use power sources which guarantee reliable electrical isolation of the operating voltage according to EN 60204-1.

Protection against electric shock (protection against direct and indirect contact) is guaranteed in accordance with EN 60204-1 by using PELV circuits (electrical equipment of machines, general requirements). The 24 V power supply unit used in the system must satisfy the requirements of EN 60204-1 for DC power supply (behaviour during power interruptions, etc.).

The cable is connected via a plug, making it easier to replace the safety module.



Make sure that no jumpers or the like can be inserted parallel to the safety wiring, e.g. through the use of the maximum wire cross section of 1.5 mm² or suitable wire end sleeves with insulating collars.

Use twin wire end sleeves for looping through lines between neighbouring devices.

3.2.2 ESD protection

With non-assigned plug connectors, there is a danger of the device that other parts of the system may be damaged as a result of ESD (electrostatic discharge). Earth the system parts prior to installation and use suitable ESD equipment (e.g. shoes, earthing straps, etc.).

3.2.3 Connection [X40]

The FSM 2.0 – STO safety module has a combined interface for control and acknowledgment via the plug connector [X40].

- Type on device: PHOENIX MINICOMBICON MC 1,5/8-GF-3,81 BK
- Plug (supplied as standard): PHOENIX MINICOMBICON MC 1,5/8-STF-3,81 BK, connection corresponds to Section 7.1.4, Table 28.

Plug	Pin	Designation	Value	Description
	8	0V	0 V	Reference potential for auxiliary power supply.
	7	24V	+24 V DC	Auxiliary power supply (24 V DC logic supply of the servo drive carried out).
	6	C2	-	Feedback contact for the status “STO” on an external controller.
	5	C1		
	4	0V-B	0 V	Reference potential for STO-B.
	3	STO-B	0 V / 24 V	Control port B for the function STO.
	2	0V-A	0 V	Reference potential for STO-A.
	1	STO-A	0 V / 24 V	Control port A for the function STO.

Table 9: Pin assignment [X40]

In order to ensure the STO “Safe Torque Off” functions correctly, the control ports STO-A and STO-B are to be connected in two channels with parallel wiring → section 3.3.1, Figure 8.

This interface can be part of an emergency stop circuit or a protective door arrangement, for example.

3.2.4 Minimum wiring for commissioning [X40]

If a safety oriented interface is (still) not present, the fieldbus activation module FSM 2.0 – FBA should be used.



The module replacement must be configured and acknowledged in the item Motion Soft™ : → Section 4.3.

Also observe the DIP switch setting: → Section 4.2 if applicable.

If no fieldbus activation module is available or for the initial start-up of the servo drive without safety equipment, the item C Series with the safety module FSM 2.0 – STO can be equipped with an emergency stop switch (2) with minimum wiring as per Figure 8.



Note

Safety functions must never be bypassed.

Carry out the minimum wiring of the inputs STO-A/STO-B and 0V-A/0V-B for the initial start-up so that it will be forcibly removed when the final protection wiring is executed.

3.3 Typical circuits

3.3.1 Safe Torque Off (STO)

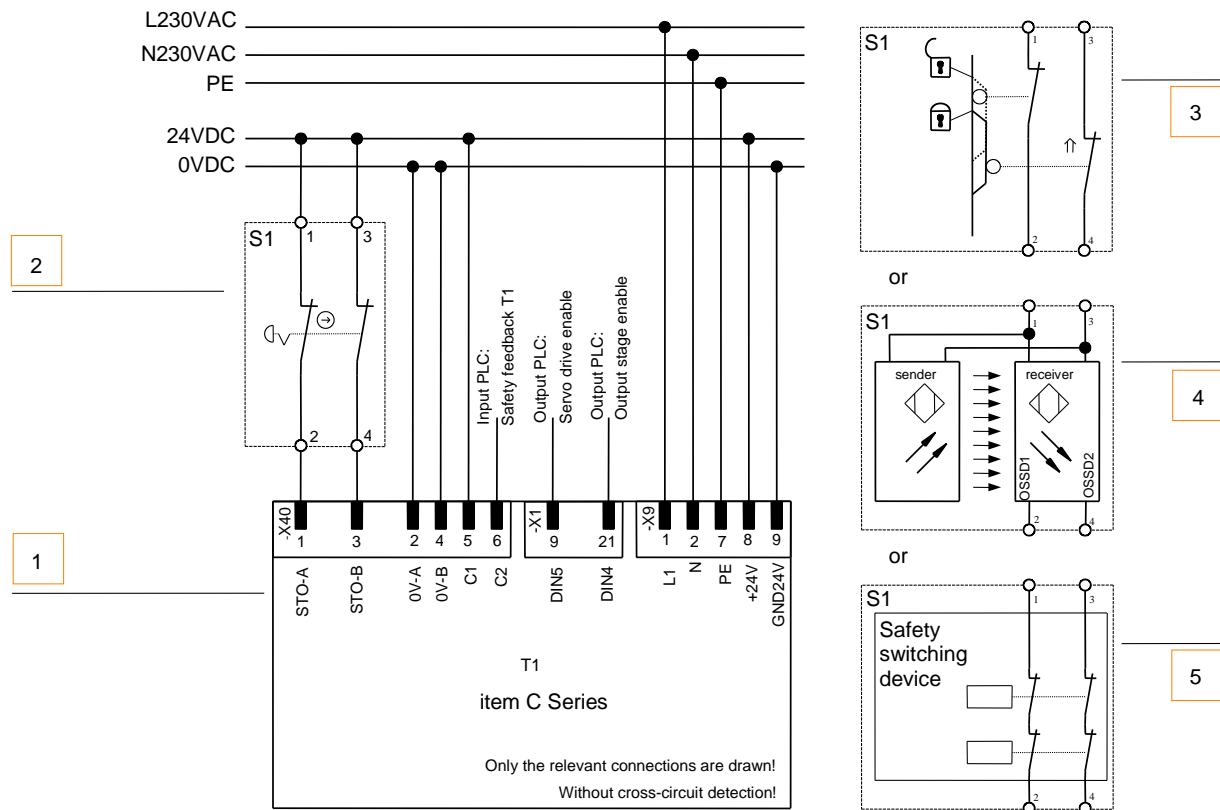

- 1 Servo drive with safety module
(only relevant connections illustrated)
- 2 Emergency stop switch
- 3 Protective door
- 4 Light curtain
- 5 Safety switching device

Figure 8: Connection of the safety module FSM 2.0 - STO, example of single-phase item C 1-Series

The safety function “Safe Torque Off” (STO) can be requested via various devices. The switch S1 can be, for example, an emergency stop switch, a safety door switch, a light barrier or a safety switching device. The safety request is made in 2 channels via switch S1 and routes to the 2-channel switch-off of the output stage. Once the output stage has been switched off, it is output by the floating contact C1/C2.

Notes with regard to a typical circuit:

- The servo drive with safety module does not have integrated cross-circuit detection. With direct light barrier wiring, the light barrier detects cross-circuits if designed to do so.
- When using safety switching devices, the contacts C1, C2 can be integrated in the feedback circuit of the safety switching device.
- The typical circuit shows a 2-channel structure, which is suitable for categories 3 and 4 with additional measures.

– Which additional measures are required depends on the range of applications and the safety concept of the machine.

3.3.2 Delays and safe torque switch off (SS1, “Safe Stop 1”)

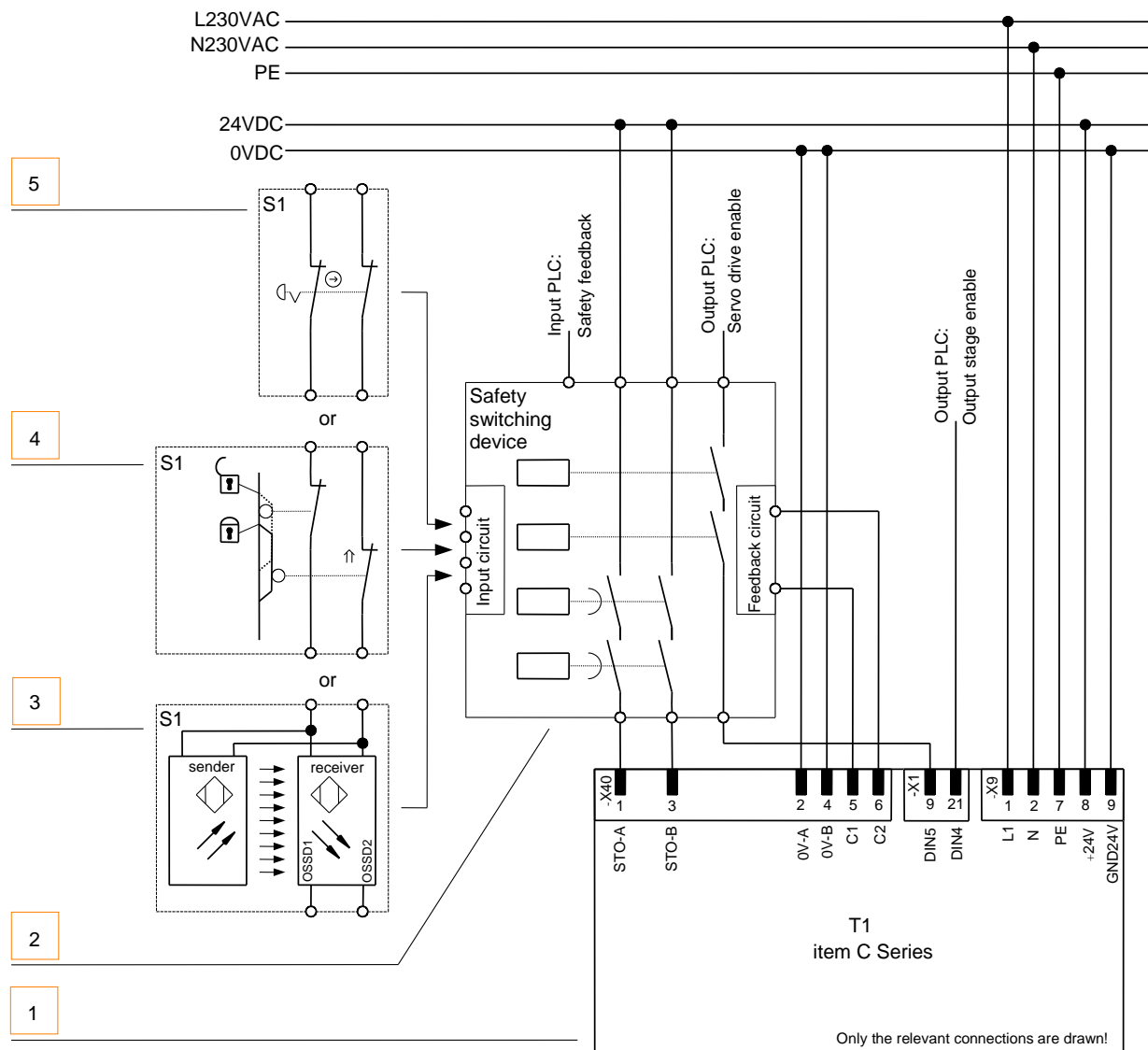

- 1 Servo drive with safety module
(only relevant connections illustrated)
- 2 Safety switching device
- 3 Light curtain
- 4 Protective door
- 5 Emergency stop switch

Figure 9: Typical circuit “Decelerate and safe torque off” (SS1, “Safe Stop 1”), example single-phase item C 1-Series

The safety function “Safe Stop 1” (SS1, type C) can be requested via various devices: → Figure 9. The switch S1 in Figure 9 can be, for example, an emergency stop switch, a safety door switch or a light barrier. The safety request is made in 2-channels via switch S1 and to the safety switching device. The safety switching device switches off the servo drive enable. If the servo drive enable switched off, the movement is automatically delayed and, if the brake is configured, brake activation is

expected before the control circuit is switched off. After a time set in the safety switching device, the 2-channel output stage is switched off via STO-A/B. Once the output stage has been switched off, it is output by the floating contact C1-C2.

Notes with regard to a typical circuit:

- The safety switching device used must switch off the servo drive enable (X1-9, DIN5) without a delay and the inputs STO-A and STO-B (X40-1, -3) with a delay.
- The required delay is application-dependent and must be defined specific to the application concerned. The delay must be designed so that the drive is decelerated to zero, even at maximum speed, via the quick stop ramp in the item C Series, before STO-A/B are switched off.
- The electrical installation is executed in accordance with the requirements of EN 60204-1.
For example, the safety switching device and the servo drive are located in the same control cabinet, so that faults can be excluded for a cross-circuit or earth fault between the cables (acceptance test on the control cabinet for faultless wiring).
- The typical circuit exhibits a 2-channel structure, which is suitable for categories 3 and 4 with additional measures.
- Which additional measures are required depends on the range of applications and the safety concept of the machine.

4 Commissioning



Note

Danger in the event of loss of the safety function!

Lack of the safety function can result in serious, irreversible injuries, e.g. due to uncontrolled movements of the connected actuators.

- Operate the safety module only:
 - in a built-in condition and
 - when all safety measures have been implemented.
- Validate the safety function to complete commissioning: → Section 4.4.



Incorrect wiring, use of an incorrect safety module or external components that were not selected according to the safety category, result in loss of the safety function.

Carry out a risk evaluation for your application and select the circuitry and components accordingly.

Note the examples → Section 3.3.

4.1 Before commissioning

Perform the following steps to prepare for commissioning:

1. Ensure that the safety module is correctly mounted (see Section 3.1).
2. Check the electrical installation (connecting cable, pin allocation → Section 3.2). Are all protective earth conductors connected?

4.2 DIP switch setting

DIP switches for activating and controlling the fieldbus configuration are located on the safety module.

The functionality of the DIP switch is identical to that of the fieldbus activation module FSM 2.0 – FBA and independent of the fieldbus interface used.



Set the DIP switches as described in the documentation for the item servo positioning controller C Series or the corresponding fieldbus-specific product manuals → Table 1, page 11.

4.3 Parameterisation with item Motion Soft™

Functional safety depends on modifications being traceable. To guarantee this, the specifications for module type, serial number and version are stored in the integrated Functional Safety Module FSM 2.0. These data are stored in the item servo positioning controller C Series as comparison values, enabling a modification to the components to be detected.

When a modification is detected, e.g. a module replacement, a non-acknowledgeable error is triggered. To be able to place the application with the servo drive back in operation, the modification must be “configured”. That means, the modification must be explicitly accepted or confirmed. With the integrated Functional Safety Modules FSM 2.0 – STO and FSM 2.0 – FBA, these traceable modifications relate to a module replacement.

The configuration is performed in the window **Safety module** of the item Motion Soft™, see Section 4.3.3 Window “Safety module”.



Abbildung 1: Menu navigation to Safety-module

The item Motion Soft™ parameterisation software has been expanded for the use of the item servo positioning controller C Series with an integrated Functional Safety Module.

The main additions are:

Type indication of the integrated Functional Safety Module FSM 2.0

Status indication for the state machine of the firmware in the item C Series

Functions for configuring the combination of integrated Functional Safety Module FSM 2.0 and item servo positioning controller C Series.

Support of the specified warnings and error messages



The Functional Safety Module FSM 2.0 – STO itself does not have to be parameterised.

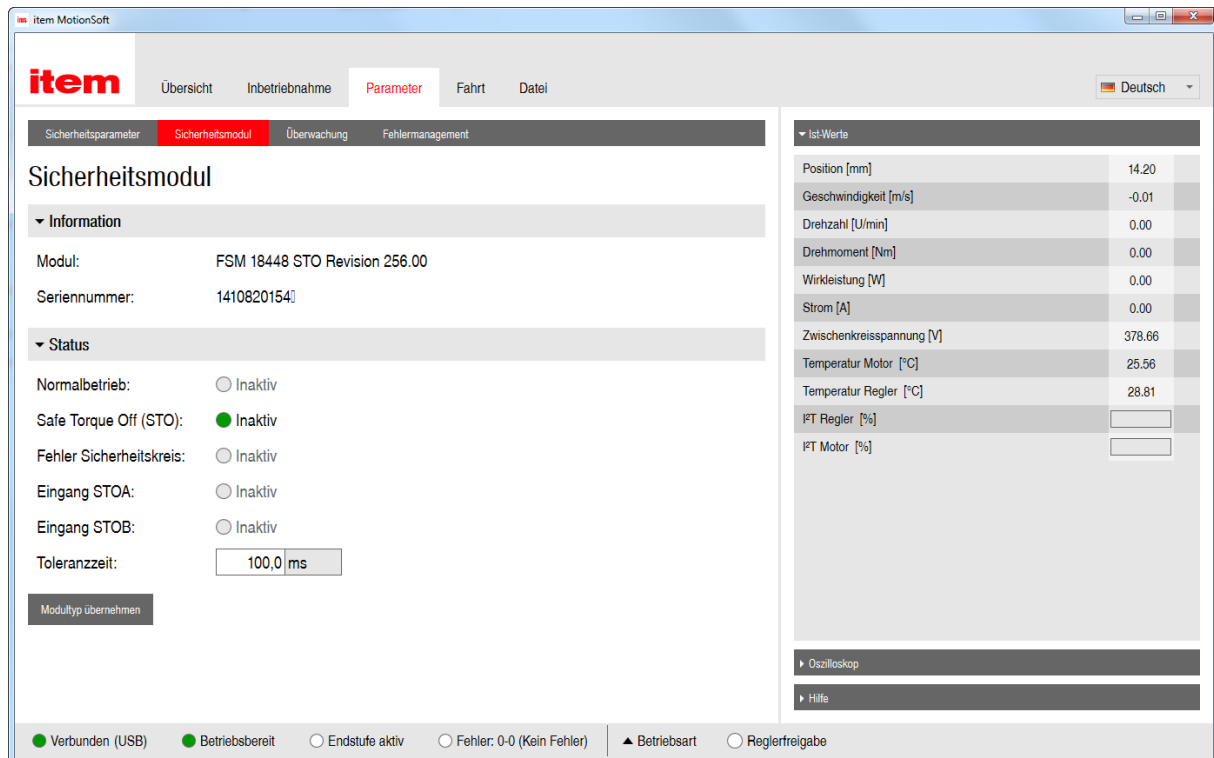

Figure 10: Indication of the type of safety module and extended status window

4.3.1 Type indication servo drive and safety module

At the lower edge of the item Motion Soft main screen, there is a **status bar**. It shows the operating status and errors, see Figure 10.

Additionally, type and serial number are indicated in the window **Safety module**; see Section 4.3.2 Status indication of the state machine.

4.3.2 Status indication of the state machine

The **Status window** (i.e. the window that is permanently displayed in the online mode) has been extended by the **status indication of the state machine**. It shows the status of the functional safety in the firmware of the item C Series, see Figure 10.

Istwerte

0.000 Nm Drehmoment

-0.006 mm/s Drehzahl

14.201 mm Position

Betriebsbereit

Endstufe aktiv

Endschalter links

Endschalter rechts

Safety Status

Normalbetrieb

Fehler

Kein Fehler

Fehler quittieren

Betriebsart

Drehmoment

Drehzahlregelung

Positionierung

Reglerfreigabe

12 %

This is not the status indication of the safety module FSM 2.0 – STO itself. Here, the status of the state machine within the item C Series resulting from the evaluation of the driver supply voltages by the safety module FSM 2.0 – STO is displayed. Independently of the display the power end stage of the item C Series may be already safely switched off by the Functional Safety Module FSM 2.0 – STO, see also Section 4.3.3.2 Status-LEDs.

In addition, the status of the internal state machine is indicated in the window **Safety module**; see Section 4.3.3 Window “Safety module”.

4.3.3 Window “Safety module”

In order to use the item C Series servo drives with an integrated Functional Safety Module, the window **Safety module** has been added to the item Motion Soft parameterisation software.

This window can be opened via the menu **Parameters – Safety – Safety-module**, see Figure 11.



Figure 11: Menu navigation to Safety-module

The window “Safety module” is divided into different fields:

4.3.3.1 Info

This field displays the device data that have been stored on the Functional Safety Module during factory commissioning:

- **Module:**
Exact type designation, for example "FSM 2.0 - STO".
- **Serial number:**
The serial number is assigned during production and is stored on the module. The serial number is unique for a product of the applicable type.

4.3.3.2 Status-LEDs

The upper three LEDs show the state of the state machine within the item C Series, see Table 10. The state is read out from the item C Series via communication objects and then displayed.

The lower two LEDs display the status of the driver supply voltage.

Status display	Meaning	State
<input type="radio"/> Normal operation <input type="radio"/> Safe Torque Off (STO) <input type="radio"/> Safety circuit error	All LEDs Off: The Functional Safety Module is not initialized / not operational.	-
<input checked="" type="radio"/> Normal operation <input type="radio"/> Safe Torque Off (STO) <input type="radio"/> Safety circuit error	Normal operation, that is "non-safe state". The module FSM 2.0 – STO is initialized error-free and operational.	Z2, Z3
<input type="radio"/> Normal operation <input checked="" type="radio"/> Safe Torque Off (STO) <input type="radio"/> Safety circuit error	"Safe state" SAFE TORQUE OFF, this means that the power output stage of the item C Series is reliably switched off.	Z1
<input type="radio"/> Normal operation <input type="radio"/> Safe Torque Off (STO) <input checked="" type="radio"/> Safety circuit error	The safety conditions are violated. The detected state of the two driver supply voltages does not comply with any of the defined valid states. The PWM has been deactivated, the power output stage is not reliable switched of, that means that the system is in a "non-safe state".	Z4

Table 10: Meaning of the LEDs for the status display in the window “Safety module”

4.3.3.3 Apply module type

In the lower part of the window **Safety module** you find the button **Apply module type**:

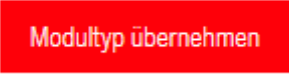

Modultyp übernehmen

Click on this button to confirm a module replacement. Thereby, the integrated functional safety is parameterised or projected. An existent error message due to a module replacement will not be generated again after Save and Reset.

4.4 Function test, validation



Note

The STO function must be validated after the installation and after changes to the installation.

This validation must be documented by the person performing commissioning. To assist you with the commissioning, questions for risk minimisation are summarised below in the form of sample checklists.



The checklists below are no substitute for safety training.

No guarantee can be provided for the completeness of the checklist.

No.	Questions	Correct	Completed
1.	Were all operating conditions and interventions taken into account?	Yes <input type="checkbox"/> No <input type="checkbox"/>	<input type="checkbox"/>
2.	If the "3-step method" for risk minimisation was applied, i. e. 1. Inherently safe design, 2. Technical and possibly additional safety measures, 3. User information on the residual risk?	Yes <input type="checkbox"/> No <input type="checkbox"/>	<input type="checkbox"/>
3.	Were the hazards eliminated or the hazard risk reduced as far as practically possible?	Yes <input type="checkbox"/> No <input type="checkbox"/>	<input type="checkbox"/>
4.	Can it be guaranteed that the implemented measures will not pose new hazards?	Yes <input type="checkbox"/> No <input type="checkbox"/>	<input type="checkbox"/>
5.	Have the users been adequately informed and warned about the residual risks?	Yes <input type="checkbox"/> No <input type="checkbox"/>	<input type="checkbox"/>
6.	Can it be guaranteed that the operators' working conditions have not deteriorated due to the safety measures taken?	Yes <input type="checkbox"/> No <input type="checkbox"/>	<input type="checkbox"/>
7.	Are the safety measures taken mutually compatible?	Yes <input type="checkbox"/> No <input type="checkbox"/>	<input type="checkbox"/>
8.	Was adequate consideration given to the potential consequences of using a machine designed for commercial/industrial purposes in a non-commercial/industrial area?	Yes <input type="checkbox"/> No <input type="checkbox"/>	<input type="checkbox"/>
9.	Can it be guaranteed that the implemented measures will not severely impair the machine's ability to perform its function?	Yes <input type="checkbox"/> No <input type="checkbox"/>	<input type="checkbox"/>

Table 11: Questions for validation in accordance with EN ISO 12100-1:2010 (example)

No.	Questions	Correct	Completed
1.	Has a risk assessment been conducted?	Yes <input type="checkbox"/> No <input type="checkbox"/>	<input type="checkbox"/>
2.	Have an error list and a validation plan been drawn up?	Yes <input type="checkbox"/> No <input type="checkbox"/>	<input type="checkbox"/>
3.	Was the validation plan, including analysis and inspection, processed and a validation report compiled? The validation procedure must include the following inspections as a minimum:	Yes <input type="checkbox"/> No <input type="checkbox"/>	<input type="checkbox"/>
	a) Component check: Is the item C Series used with the FSM 2.0 – STO (inspection using the rating plates)	Yes <input type="checkbox"/> No <input type="checkbox"/>	<input type="checkbox"/>
	b) Is the wiring correct (check against the wiring diagram)?	Yes <input type="checkbox"/> No <input type="checkbox"/>	<input type="checkbox"/>
	– Have any short-circuit bypasses been removed?	Yes <input type="checkbox"/> No <input type="checkbox"/>	<input type="checkbox"/>
	– Has a safety switching device been wired to X40?	Yes <input type="checkbox"/> No <input type="checkbox"/>	<input type="checkbox"/>
	– Is the safety switching device certified and wired in accordance with the application's requirements?	Yes <input type="checkbox"/> No <input type="checkbox"/>	<input type="checkbox"/>
	c) Functional inspections:	Yes <input type="checkbox"/> No <input type="checkbox"/>	<input type="checkbox"/>
	– Pressing the emergency stop button on the unit. Is the drive shut down?	Yes <input type="checkbox"/> No <input type="checkbox"/>	<input type="checkbox"/>
	– If only STO-A is activated - is the drive shut down immediately and the "discrepancy time violation" error (Display 52-1) reported in the item C Series after the discrepancy time has lapsed?	Yes <input type="checkbox"/> No <input type="checkbox"/>	<input type="checkbox"/>
	– If only STO-B is activated - is the drive shut down immediately and the "discrepancy time violation" error (Display 52-1) is reported in the item C Series after the discrepancy time has lapsed?	Yes <input type="checkbox"/> No <input type="checkbox"/>	<input type="checkbox"/>
	– Is a short circuit detected between STO-A and STO-B or has a suitable fault exclusion been defined?	Yes <input type="checkbox"/> No <input type="checkbox"/>	<input type="checkbox"/>
	– Only when using a safety switching device with analysis of the feedback contact C1/C2: Is the drive shut down on a short-circuit from C1 to C2?	Yes <input type="checkbox"/> No <input type="checkbox"/>	<input type="checkbox"/>
	– Is a restart inhibited? I.e. no movement occurs when the emergency stop button is pressed and the enable signals are active unless a start command is acknowledged beforehand.	Yes <input type="checkbox"/> No <input type="checkbox"/>	<input type="checkbox"/>

Table 12: Questions for validation in accordance with EN ISO 13849-1 and 2 (example)

5 Operation

5.1 Obligations of the operator

The operational capability of the safety equipment must be checked at adequate intervals. It is the responsibility of the operator to choose the type of check and time intervals in the specified time period. The check must be made in a way that proves proper functioning of the safety equipment in interaction with all components.

5.2 Maintenance and care

The safety module does not require any maintenance.

5.3 Protective functions

5.3.1 Voltage monitoring

The input voltages at STO-A and STO-B are monitored. If the input voltage at STO-A or STO-B is too high or too low, the driver supply for the power semiconductors of the servo drive are safely switched off. The power output stage (PWM) is thus switched off.

5.3.2 Protection against overvoltage and reverse polarity

The control inputs STO-A and STO-B are protected against overvoltage and reverse polarity of the control voltage → Section 7.1.4, Table 23.

The 24 V DC supply voltage for the servo drive routed to [X40] is short-circuit resistant.

5.4 Diagnostics and troubleshooting

5.4.1 Status indicators

5.4.1.1 Display on the safety module

The operating status is displayed on the two-colour LED of the safety module.

LED	Status	Description
Off	Not safe = STO status not active	Safety module or servo drive has no operating voltage.
Green	Not safe = STO status not active	The power output stage in the servo drive for supply of the motor can be active or inactive.
Yellow	Safe = STO status active	The power output stage in the servo drive for supply of the motor is switched off safely.

Table 13: LED display on the safety module

5.4.1.2 Display on the servo drive

Display	Description
	<p>"H": The servo drive is in the "safe status".</p> <p>This does not have the same meaning as the information on the status of the safety function STO (Safe Torque Off). This can only be read off on the LED of the safety module.</p> <p>No special display is intended for the "unsafe status"; the normal status displays of the servo drive are represented.</p>

Table 14: Seven segment display on the servo drive

5.4.2 Error messages

When an error occurs, the servo drive shows an error message cyclically in the seven-segment display on the front of the servo drive. The error message consists of an E (for Error), a main index (xx) and sub-index (y), e.g.: E 5 1 0.

Warnings have the same number as an error message. The difference is that a warning is displayed with a prefixed and suffixed hyphen, e.g. - 1 7 0 -.

Table 15 lists the error messages that are relevant for the functional safety in combination with the safety module FSM 2.0 - STO.



For more information about other error messages, please refer to the corresponding documentation, for example the relevant product manuals, the software manual or the fieldbus- specific product manuals. See Table 1, page 11.

Where an error message cannot be acknowledged, the cause must first be remedied in accordance with the recommended measures. Then reset the servo drive, and check whether the cause of the error, and the error message, have been eliminated.

Error message		Meaning of the error message	Measures
Main index	Sub index		
51 ¹⁾	0	No / unknown safety module – No safety module or unknown module type detected	<ul style="list-style-type: none"> ▪ Install a safety module or fieldbus activation module appropriate for the firmware and hardware. ²⁾ ▪ Load a firmware suitable for the safety module or fieldbus activation module; see type designation on the module.
	1	Safety module: Faulty driver supply – Internal voltage error of the safety module or fieldbus activation module	<ul style="list-style-type: none"> ▪ Module presumably defective. If possible, replace with another module.
	2	Safety module: Different module type – Type or version of the module does not fit the design	<ul style="list-style-type: none"> ▪ For module replacement: Module type not yet in design. Accept installed safety module or fieldbus activation module, see Section 4.3.3.
	3	Safety module: Different module version – Module type or version is not supported.	<ul style="list-style-type: none"> ▪ Install a safety module or fieldbus activation module appropriate for the firmware and hardware. ²⁾ ▪ Load a firmware suitable for the module; see type designation on the module. ²⁾
52	1	Safety module: Discrepancy time expired	<ul style="list-style-type: none"> ▪ Control ports STO-A and STO-B are not actuated simultaneously. ▪ Control ports STO-A and STO-B are not wired in the same way. ▪ Check discrepancy time.
	2	Safety module: Failure of driver supply with active PWM	<ul style="list-style-type: none"> ▪ The safe status was requested with enabled power output stage. Check link to the safety-oriented interface.
<p>1) The messages of error group 51 cannot be acknowledged.</p> <p>2) See Section „Product identification on page 10.</p>			

Table 15: Error messages relating to the safety module

6 Conversion and module replacement

6.1 Safety module replacement

6.1.1 Repair



Repair of the module is not permissible. If necessary, replace the complete module.

6.1.2 Removal and installation



Information on removing and installing the safety module can be found here:

- Mounting/dismounting the safety module, see Section 3.1.
- Accept the serial number of the replaced safety module, see Section 4.3.3.

6.2 Decommissioning and disposal

Observe the information for dismantling the safety module in Section 3.1.

6.2.1 Disposal



Observe the local regulations for environmentally appropriate disposal of electronic modules.

7 Technical appendix

7.1 Technical data

7.1.1 Safety engineering

Safety indicators		
Safety function	STO	<ul style="list-style-type: none"> – Safe Restart Interlock (STO, Safe Torque Off) to EN 61800-5-2 with SIL3 – Safe Restart Interlock (STO, Safe Torque Off) to EN ISO 13849-1 with category 4 and PL e
SIL	SIL 3 / SIL CL 3	Safety integrity level according to EN 61800-5-2
Category	4	Classification in category in accordance with EN ISO 13849-1
PL	PL e	Performance level in accordance with EN ISO 13849-1
DCavg [%]	97,5	Average diagnostic coverage
HFT	1	Hardware failure tolerance
SFF [%]	99,2	Safe Failure Fraction
PFH	$1,07 \times 10^{-10}$	Probability of dangerous Failure per Hour
PFD	$2,3 \times 10^{-5}$	Probability of dangerous Failure on Demand
T [Years]	20	Proof Test Interval Duration of use in accordance with EN ISO 13849-1
MTTFd [Years]	100	Mean time to dangerous failure Calculated at 1450 years, limited to 100 years

Table 16: Technical data: Safety indicators

Safety specifications	
Product type testing	The functional safety equipment of the product was certified by an independent testing authority in accordance with Section 1.1.4; see EC product type test certificate (available at http://www.item24.com).
Certifying body	TÜV 01/205/5506.00/16
Reliable component	Yes

Table 17: Technical data: Safety specifications

7.1.2 General

Mechanical	
Length/width/height	[mm] approx. 112,6 x 87,2 x 28,3
Weight	[g] approx. 75
Slot	Slot for Functional Safety Modules
Note on materials	RoHS-compliant

Table 18: Technical data: Mechanical

Certifications (Safety module FSM 2.0 – STO for item C Series)	
CE marking (see declaration of conformity, available at http://www.item24.com).	In accordance with EU EMC Directive
	In accordance with EU machine directive
	The device is intended for industrial use. Measures for interference suppression may need to be implemented in residential areas.

Table 19: Technical data: Certification

7.1.3 Operating and environmental conditions

Transport		
Temperature range	[°C]	-25 ... +70
Air humidity	[%]	0 ... 95, at max. 40 °C ambient temperature
Maximum transportation duration		Maximum 4 weeks over the entire product life cycle

Table 20: Technical data: Transport

Storage		
Storage temperature	[°C]	-25 ... +55
Air humidity	[%]	5 ... 95, non-condensing or protected against condensation
Permissible altitude	[m]	< 3000 (above sea level)

Table 21: Technical data: Storage

Ambient conditions		
Ambient temperature	[°C]	0 ... +40 (outside the servo drive housing)
Cooling		By means of ambient atmosphere in the servo drive, no forced ventilation
Permissible setup altitude	[m]	< 2000 (above sea level)
Protection class		IP20 (mounted in the item C Series)
Air humidity	[%]	Relative air humidity up to 90 %, non-condensing
Degree of contamination in accordance with EN 61800-5-1		2 The integrated safety equipment requires compliance with degree of contamination 2 and thus a protected fitting space (IP54). This must always be ensured through appropriate measures, e.g. through installation in a control cabinet.

Table 22: Technical data: Ambient conditions

7.1.4 Electrical data

Control ports STO-A, 0V-A / STO-B, 0V-B [X40]		
Nominal voltage	[V]	24 (related to 0V-A/B)
Voltage range	[V]	19,2 ... 28,8
Permissible residual ripple	[%]	2 (related to nominal voltage 24 V)
Overvoltage discharge	[V]	31 (disconnect in case of error)
Nominal current	[mA]	20 (typical; maximum 30)
Starting current	[mA]	450 (typical, duration approx. 2 ms; max. 600 at 28.8 V)
Input voltage threshold		
Switching on	[V]	approx. 18
Switching off	[V]	approx. 12,5
Switching time from high to low (STO-A/B_OFF)	[ms]	10 (typical; maximum 20 at 28,8 V)
Switching time from low to high (STO-A/B_ON)	[ms]	1 (typical; maximum 5)
Maximum positive test impulse length at logic 0	[µs]	< 300 (related to nominal voltage 24 V and intervals, > 2 s between impulses)

Table 23: Technical data: Electrical for ports STO-A and STO-B

Switch-off time to power output stage inactive and maximum tolerance time for test pulse											
Input voltage (STO-A/B)	[V]	19	20	21	22	23	24	25	26	27	28
Typical switch-off time (STO-A/B_OFF)	[ms]	4,0	4,5	5,0	6,0	6,5	7,0	7,5	8,0	8,5	9,5
Maximum tolerance time for test pulse at 24 V signal	[ms]	<2,0	<2,0	2,0	2,5	3,0	3,5	4,5	5,0	5,5	6,0

Table 24: Typical switch-off time and minimum tolerance time for test pulse (OSSD signals)

Feedback contact C1, C2 [X40]		
Version		Relay contact, normally open
Max. voltage	[V DC]	< 30 (overvoltage-proof up to 60 V DC)
Nominal current	[mA]	< 200 (not short circuit proof)
Voltage drop	[V]	≤ 1
Residual current (contact opened)	[μA]	< 10
Switching time closing (T_C1/C2_ON)	[ms]	< (STO-A/B_OFF ¹⁾ + 5 ms)
Switching time opening (T_C1/C2_OFF)	[ms]	< (STO-A/B_ON ¹⁾ + 5 ms)
1) STO-A/B_OFF, STO-A/B_ON → Table 23		

Table 25: Technical data: Electrical data of the feedback contact C1/C2

Auxiliary supply 24V, 0V [X40] – output		
Version		Logic supply voltage routed out of the servo drive (fed in at [X9], not additionally filtered or stabilised). Reserve polarity protected, overvoltage-proof up to 60 V DC.
Nominal voltage	[V]	24
Nominal current	[mA]	100 (short circuit proof, max 300 mA)
Voltage drop	[V]	≤ 1 (for nominal current)

Table 26: Technical data: Electrical data of the auxiliary supply output

Electrical isolation	
Electrically isolated potential ranges	STO-A / 0V-A
	STO-B / 0V-B
	C1 / C2
	24V / 0V (Logic supply to the servo drive)

Table 27: Technical data: Electrical isolation [X40]

Cabling		
Max. cable length		
Unscreened	[m]	30
Screened	[m]	> 30
Screening	When wiring outside the control cabinet, use screened cable. Guide screening into the control cabinet / attach to the side of the control cabinet.	
Cable cross section (flexible conductors, wire end sleeve with insulating collar)		
One conductor	mm ²	0,25 ... 0,5
Two conductors	mm ²	2 x 0,25 (with twin wire end sleeves)
Tightening torque M2	[Nm]	0,22 ... 0,25

Table 28: Technical data: Cabling to [X40]

8 Glossary

Term/abbreviation	Description
Cat.	Safety category in accordance with EN ISO 13849-1, Stages 1-4.
CCF	Common Cause Failure in accordance with EN ISO 13849-1.
DC avg	Average Diagnostic Coverage in accordance with IEC 61508 and EN 61800-5-2.
EMERGENCY SWITCHING OFF	In accordance with EN 60204-1: Electrical safety in case of emergency by switching off the electrical energy to all or part of the installation. EMERGENCY SWITCHING OFF is to be used where a risk of electric shock or other electrical risk exists.
Emergency stop	In accordance with EN 60204-1: Functional safety in an emergency by bringing a machine or movable parts to a standstill. Emergency stop is used to stop a process or a motion if this creates a danger.
HFT	Hardware Fault Tolerance in accordance with IEC 61508.
MTTFd	Mean Time To dangerous Failure: Time in years up to the first dangerous failure occurs with 100 % probability in accordance with EN ISO 13849-1.
OSSD	Output Signal Switching Device: Output signals with 24 V cycle rates for error detection.
PFd	Probability of Failure on Demand in accordance with IEC 61508.
PFH	Probability of Dangerous Failures per Hour in accordance with IEC 61508.
PL	Performance Level in accordance with EN ISO 13849-1: Stages a ... e.
PWM	Pulse-width modulation. Here, signifies the digital activation of the power semiconductors with a variable duty cycle to allow the adjustment of a voltage at the motor output.
Safety switching device	Device for executing safety functions or restoring the machine to a safe status after the power supply to dangerous machine functions has been switched off. The desired safety function is achieved only in combination with other measures, although switch-off can occur on a servo drive, for example.
SFF	Safe Failure Fraction [%] in accordance with IEC 61508.
SIL	Safety Integrity Level, discrete stages for defining the requirements for the safety integrity of safety functions in accordance with IEC 61508, EN 62061 and EN ISO 13849.
SIL CL	Maximum SIL that can be required from a sub-system.
SS1	Safe Stop 1, according to EN 61800-5-2.
STO	Safe Torque Off in accordance with EN 61800-5-2.
T	Duration of use in accordance with EN ISO 13849-1.

Table 29: Terms and abbreviations